

FCM2630 - Pre-calibrated Module for Refrigerant Gas R-32

Features:

- * Factory calibrated
- * Temperature compensation circuit
- * Resistant to interference gases
- * Compact embedded type module

FCM2630 is an embedded type module using the semiconductor gas sensor TGS2630 which is optimized to detect the low-flammable refrigerant gas R-32.

This module enables users to easily build a reliable gas leakage detection system by eliminating electronic circuit design for temperature compensation and the calibration process. In addition, a connector allows easy replacement of the gas sensor module for periodic maintenance.

The TGS2630 gas sensor has a built-in filter to reduce the influence of alcohol and other interference gases, resulting in high selectivity to R-32. For more detailed information on the gas sensor, including sensitivity characteristics, see *TGS2630 Product Information*.

FCM2630 is capable of satisfying the JRA4068:2016 standard (Performance 3) established by the Japan Refrigeration and Air Conditioning Industry Association.

Applications:

- * Refrigerant gas leak detection in air conditioning/refrigeration systems



Circuit Diagram

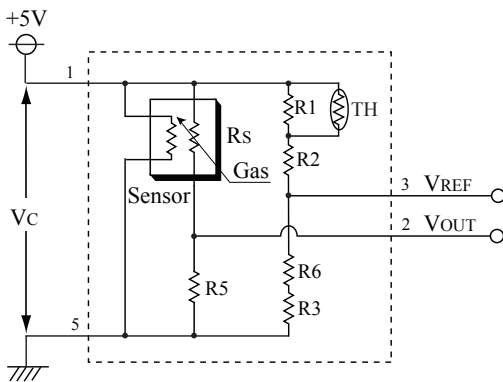

VC: Circuit voltage
 VOUT: Output voltage
 VREF: Reference voltage

Pin Connections

Pin No.	Name	Description
1	Vc	Circuit voltage
2	Vout	Output voltage
3	VREF	Reference voltage
4	-	-
5	GND	Common ground

Connector model: S05B-PASK-2 (made by JST)
 Recommended receptacle for connector: PAP-05V-S (made by JST)

ApolloSense Ltd

Specifications

Model No.		FCM2630
Gas sensor		TGS2630
Target gases		Refrigerant gas R-32
Circuit voltage	V _c	5.0±0.2V DC
Output voltage	V _{OUT}	2.5±1.0V in 5000ppm R-32 (under standard test conditions) Malfunction condition: V _{OUT} < 0.05V or V _{OUT} > 4.95V (V _c = 5.00V)
Reference voltage	V _{REF}	2.5±1.0V (under the standard test conditions) Malfunction condition: V _{REF} < 0.50V or V _{REF} > 4.00V (V _c = 5.00V)
Initial alarm accuracy	2800-9000ppm R-32 (under standard test conditions) Alarm state: V _{OUT} ≥ V _{REF} Normal state: V _{OUT} < V _{REF}	
Warm-up time	≤60 seconds (time before V _{OUT} < V _{REF} after power is turned on in a clean atmosphere)	
Operating conditions	-10°~+50°C, 20-95%RH (avoid condensation)	
Power consumption	approx. 0.3W	
Weight	approx. 4g	
Dimensions	25 x 25 x 17mm	
Standard test conditions	Test gas conditions	20°±2°C, 65±5%RH
	Circuit conditions	V _c = 5.00±0.05V DC
	Conditioning period prior to test	≥1 day

NOTE: If the internal temperature near the gas sensor module becomes higher than the external ambient temperature by 10°C or more due to heat generated by electronic components in a device into which this gas sensor module is incorporated, the set alarm threshold may drift due to change of the reference voltage (V_{REF}). Please consult with Figaro if there is difficulty in designing a device so as to keep the temperature rise inside the device within 10°C.

Structure and Dimensions

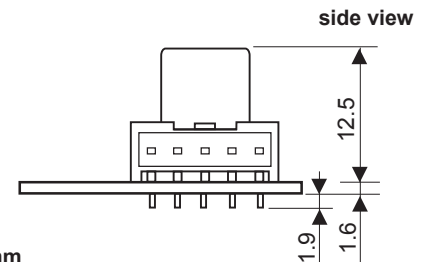
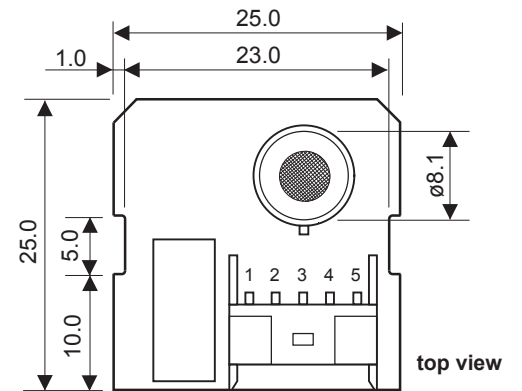

u/m: mm

Figaro Engineering Inc. reserves the right to make changes without notice to this product to improve reliability, functioning, or design.

ApolloSense Ltd